

Installation Guide

mTS1000 WP Series Tripod Turnstile

Version: 1.1

1 Installation Requirements

1. It is recommended that the tripod turnstile must be installed on a horizontal solid platform with a height of 50mm to 100mm.
2. It is also recommended that the tripod turnstile should not be used in the corrosive environment.
3. Make sure the ground wire of the system is reliably connected to avoid personal injuries or other accidents.
4. After installation, check if the connection has been done correctly at the connecting points of the ground wire, at the connector assemblies and wiring points of the circuits, as well as at each movable part of the tripod turnstile. Any loose nuts, screws and other fasteners should be tightened in time to avoid any failures caused by long-time operations.

2 Installation Environment

The installation position of the tripod turnstile depends on its size. A distance of 100mm between the tripod turnstile and the wall needs to be reserved for ease of opening the top lid of the turnstile to perform maintenance and adjustment. The reference figure is shown below:

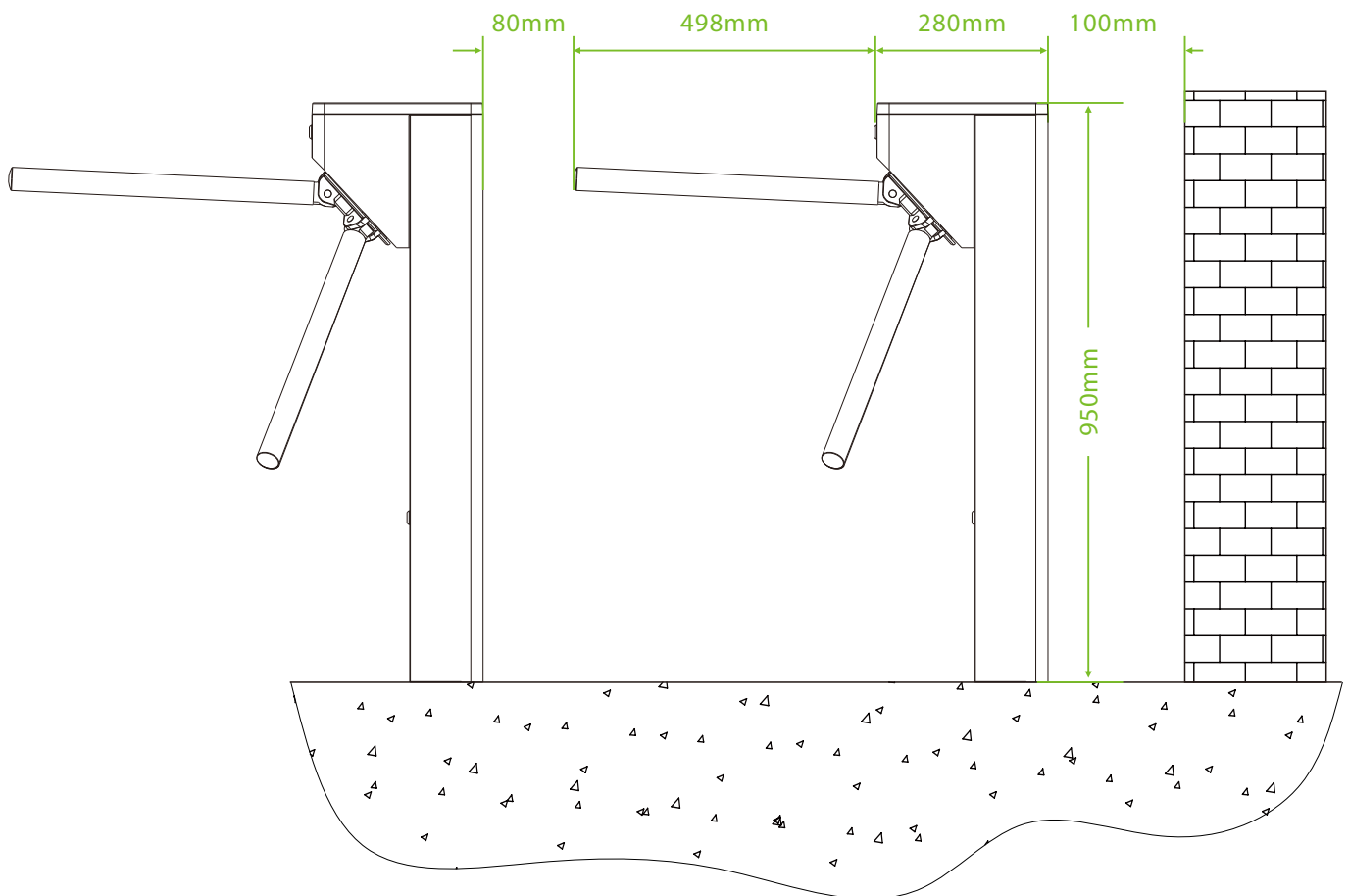

3 Preparation

To install the 1000 WP you must have:

- **A Screwdriver:** To remove or install the screw on the device.
- **A Pencil:** To mark the device size and the screw hole.
- **A Electric Drill:** To drill holes in accordance to the marked screw holes.
- **A Wrench:** To secure the M12 expansion screw on the device.
- **A Tapeline:** To measure the dimensions that need to be measured during the installation of the device.
- **A Hex Wrench:** To remove or install the screw on the device.
- **Cutting Machine:** Cutting the road, laying cables.

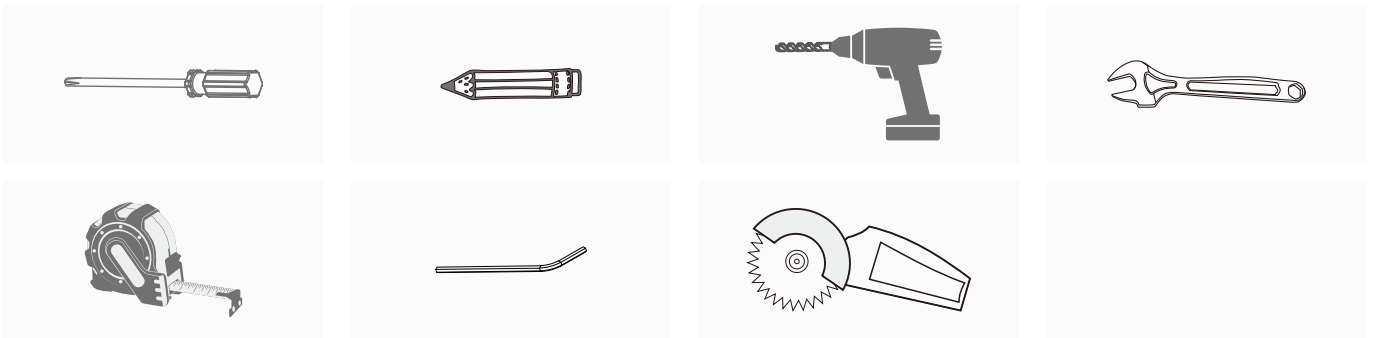

Note: Except for the hex wrench, all other tools should be prepared on your own.

4 Installation

1. Place the turnstile to the installation site.

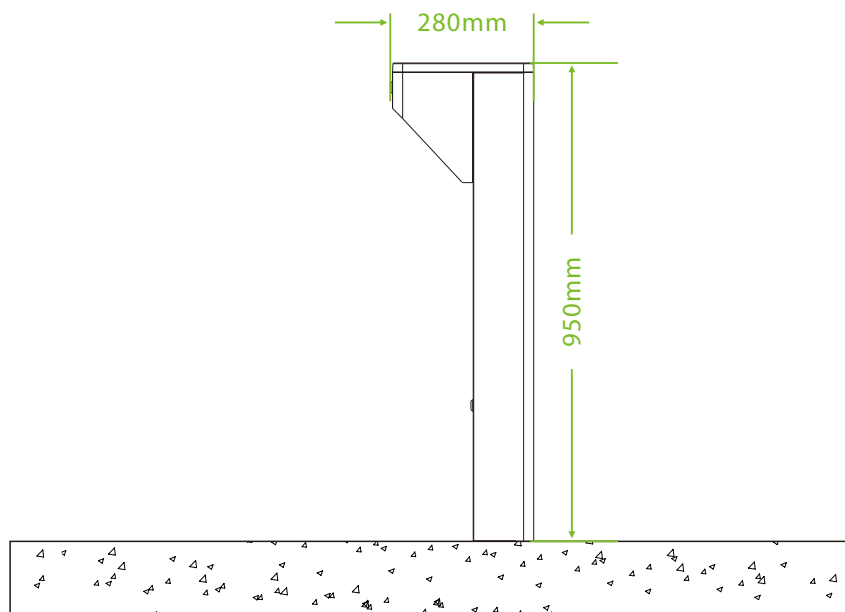

2. Use the key to open the chassis of the turnstile and remove the chassis cover.

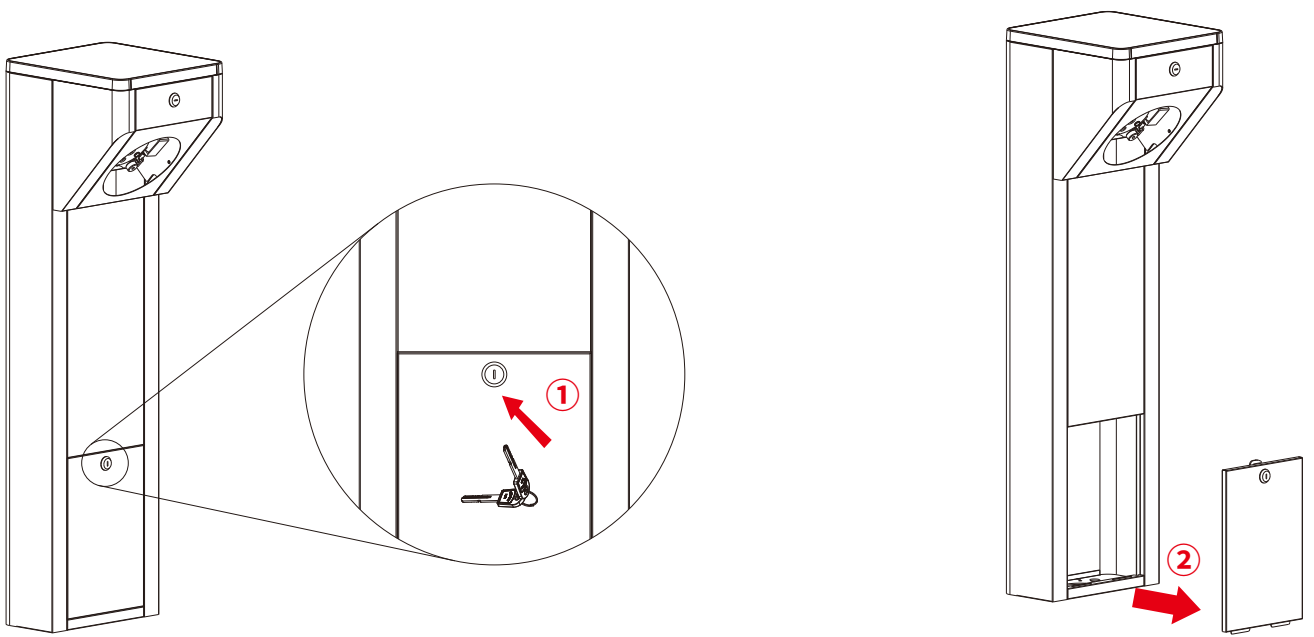

3. Mark on the turnstile with a pencil according to the holes.

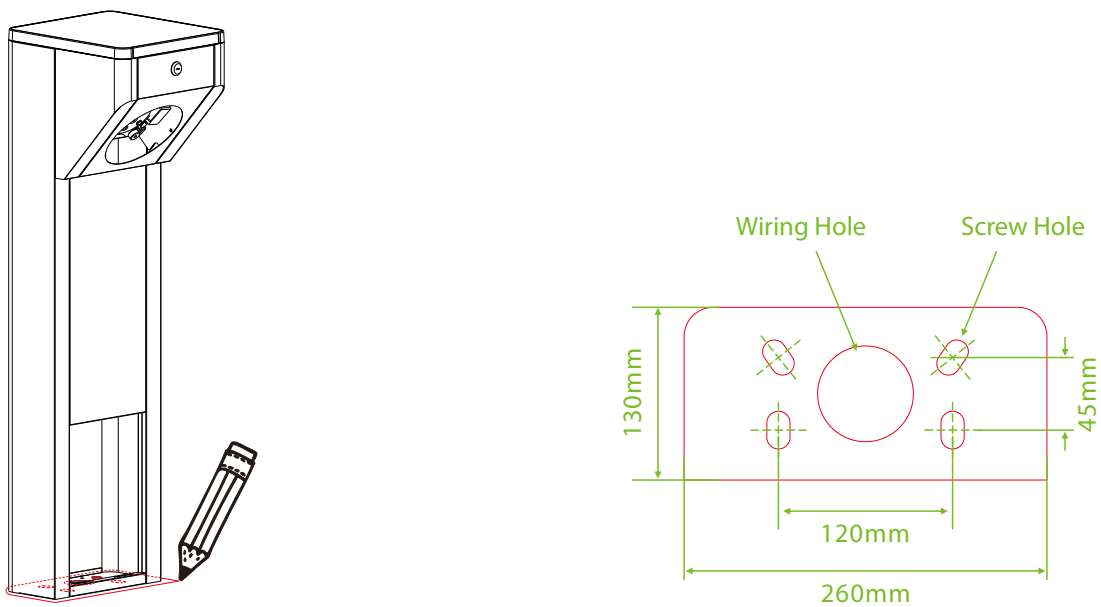

4. Remove the turnstile, according to the marks, drill holes with Electric Drill.

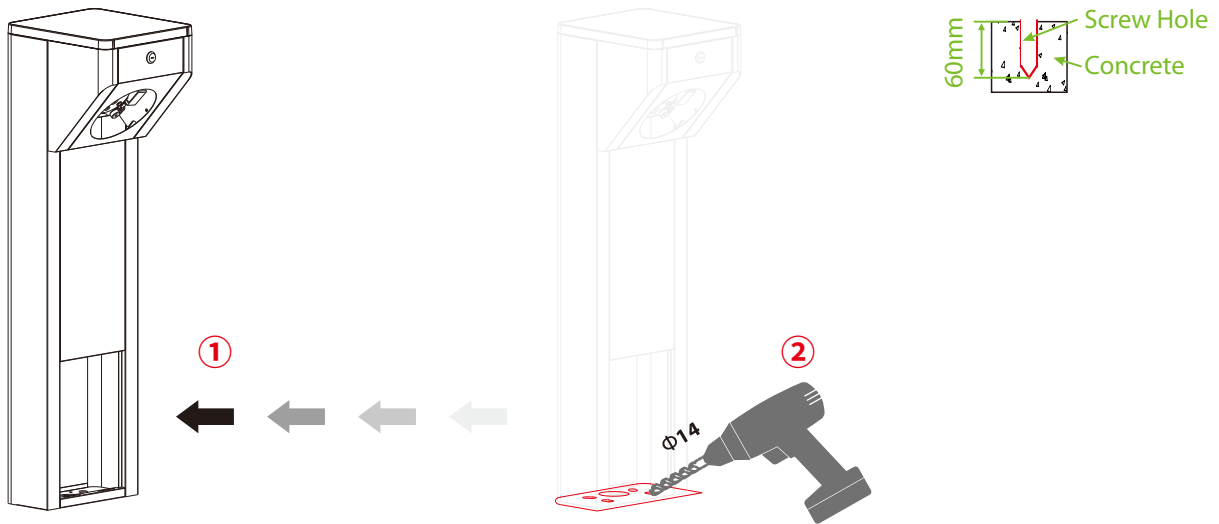

5. A slot with a width of 50 mm and a depth of 60 mm is cut with a Cutting Machine according to the wiring hole.

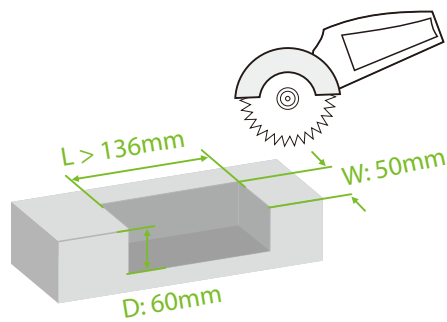

Bottom View:

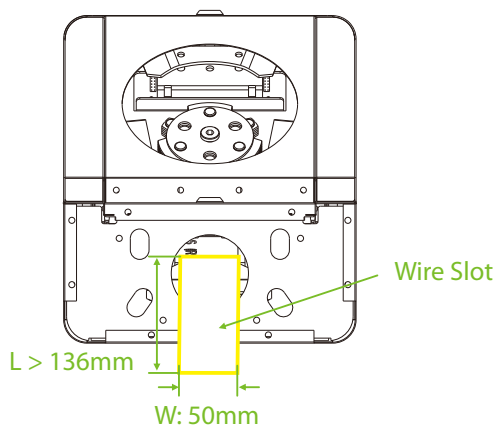

Side View:

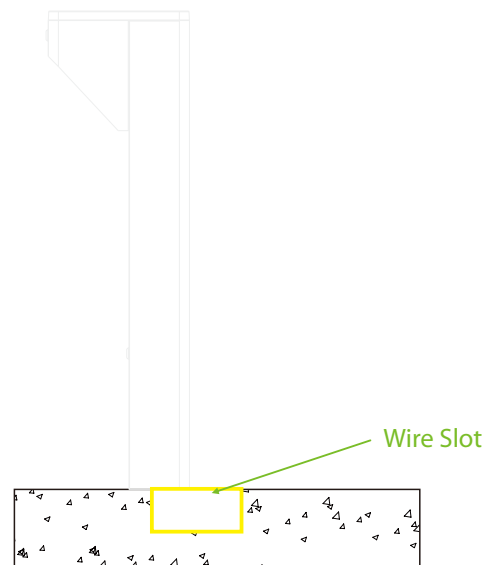

- Clean up the fragments and dust after drilling, then place the turnstile on the installation site again. Check whether the drilled holes corresponds to the mark on the turnstile.
- Laying $\phi 40\text{mm}$ PVC pipes and passing the Ethernet and Power cable through the pipes, and finally re-pouring the concrete on the road that has been cut.

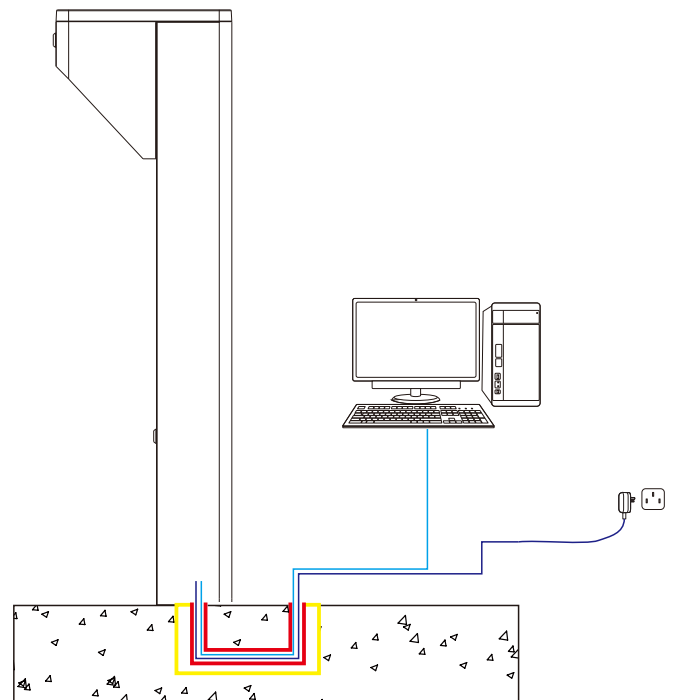
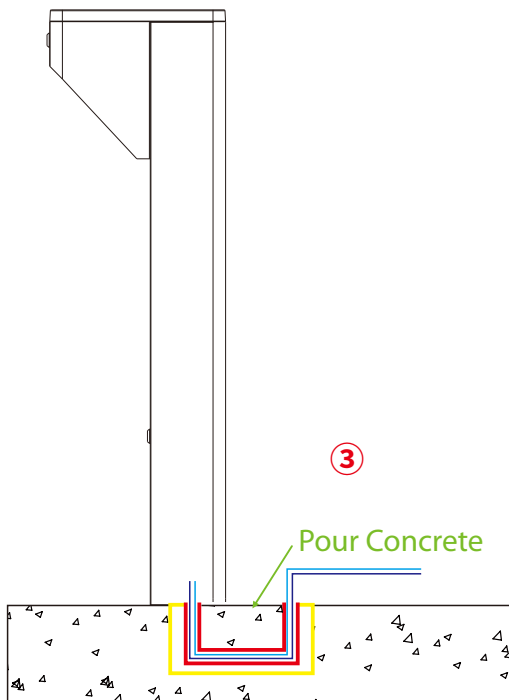
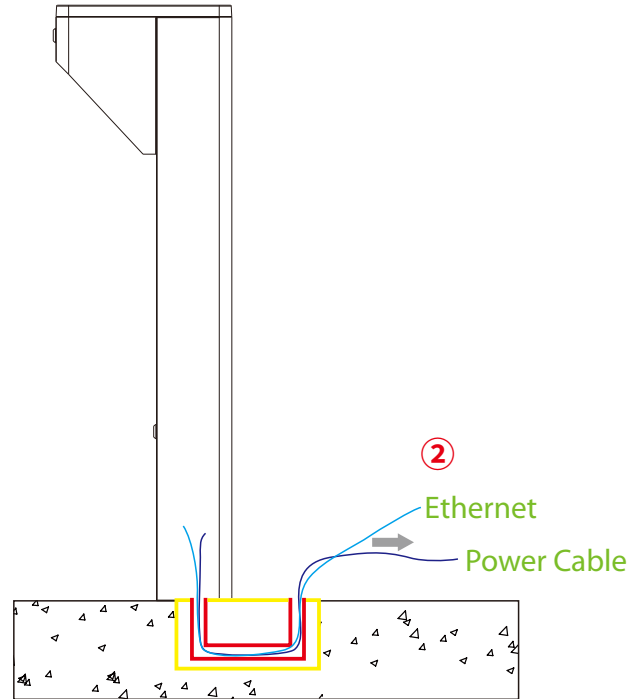
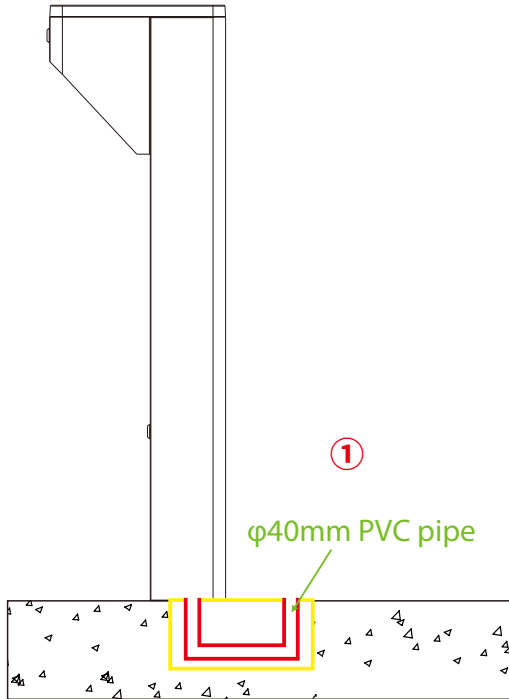

8. Align the device with the drilled holes. Then, insert the bolts accordingly and fix them with a wrench. Finally, insert the washer and nut, tighten it with a wrench.

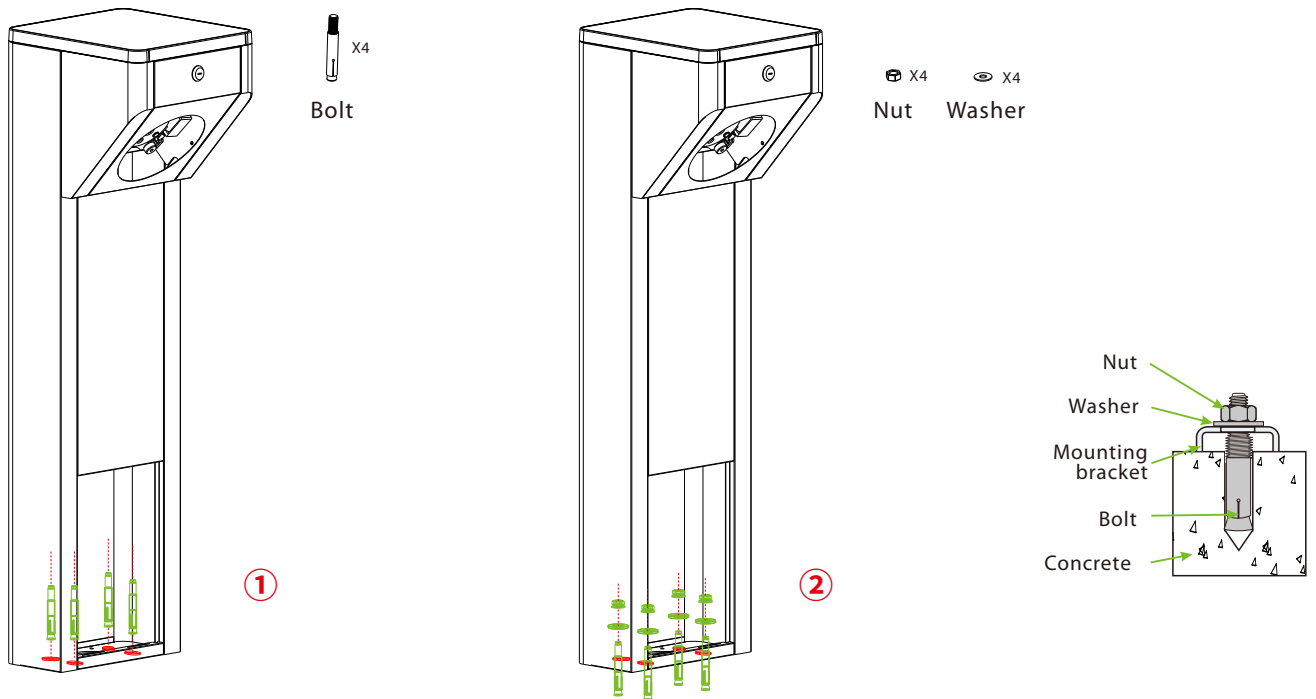

Note: Before inserting the bolt, the user must pull the power cable and Ethernet from the machines and put them into the wire slot.

9. Use the key to open the top lid of the turnstile.

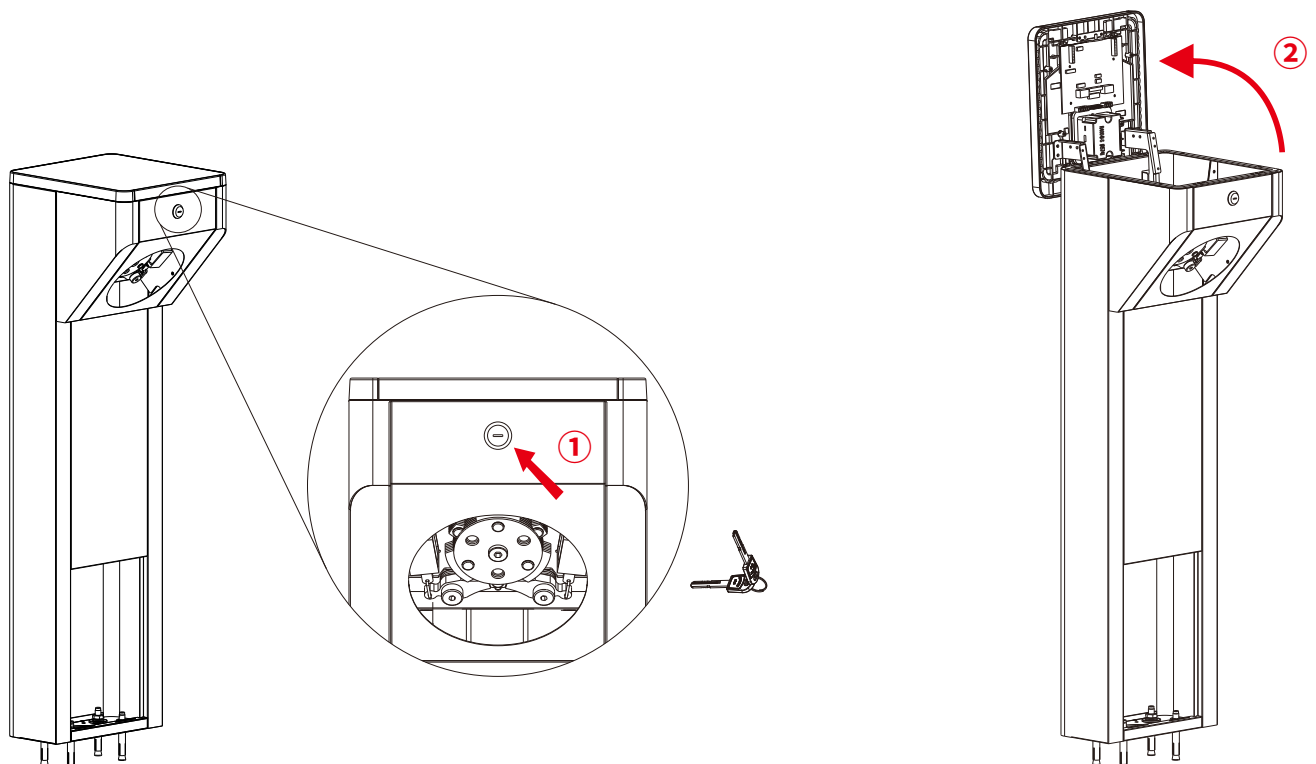

10. Align the arm assembly with the assembly inside the chassis, and then secure it with screws.

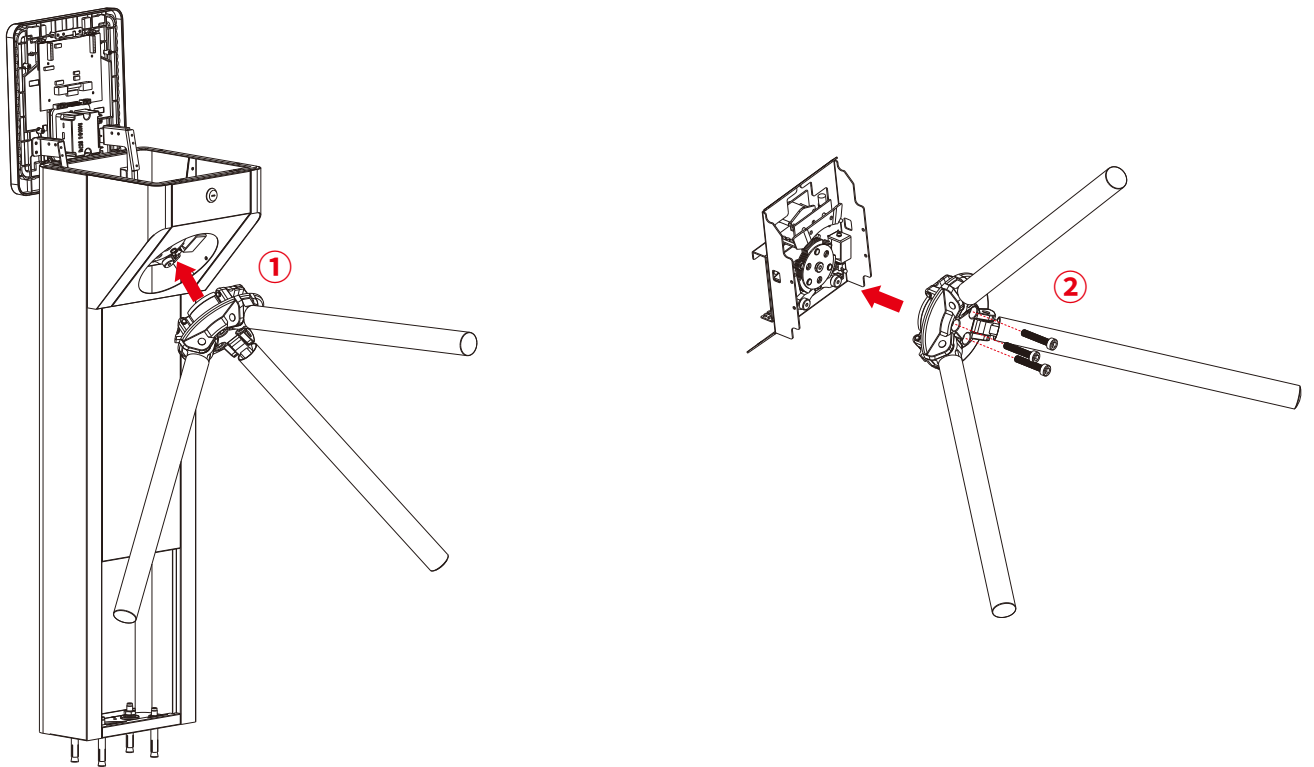

11. After assembling the arm, the resistance of the arm can be adjusted by rotating the damper left and right. Rotate the damper and observe the number on the damper. The greater the number it is, the larger the resistance will be.

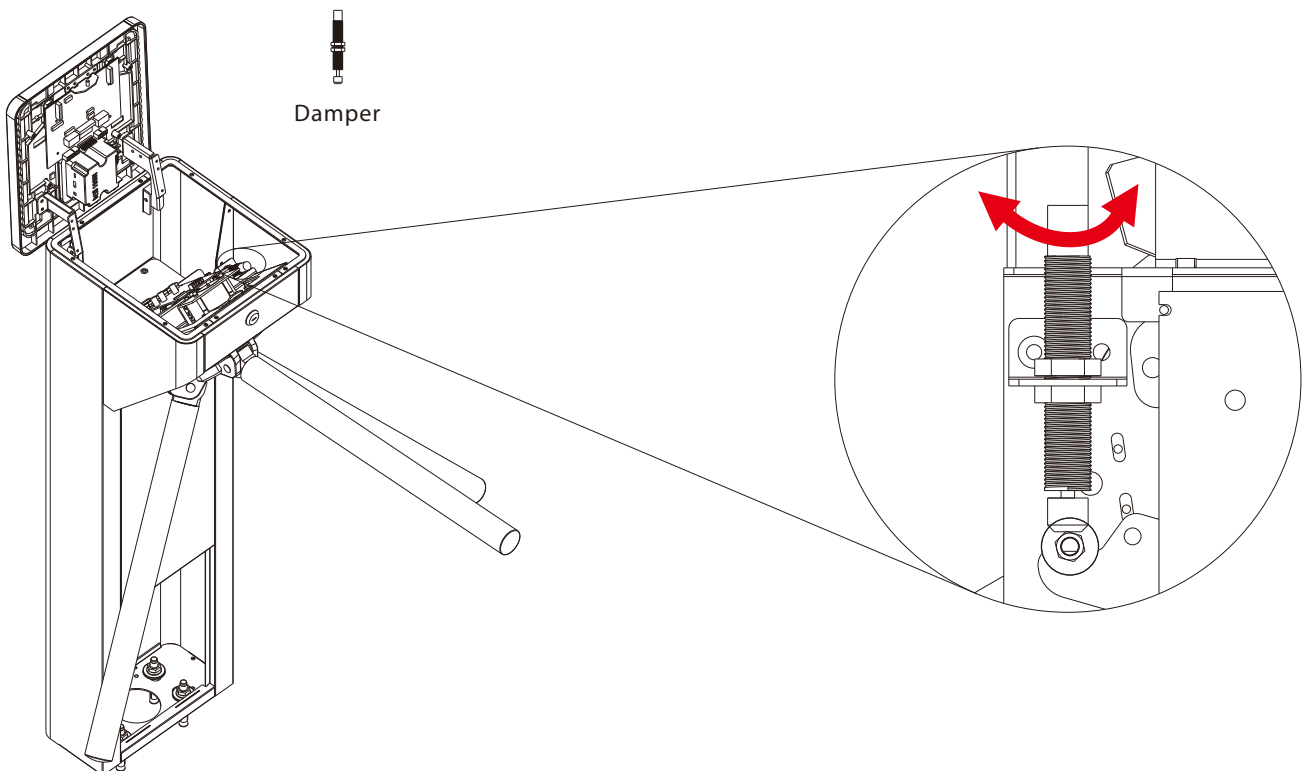

12. Install the chassis cover and close the top lid, then lock it with the key.

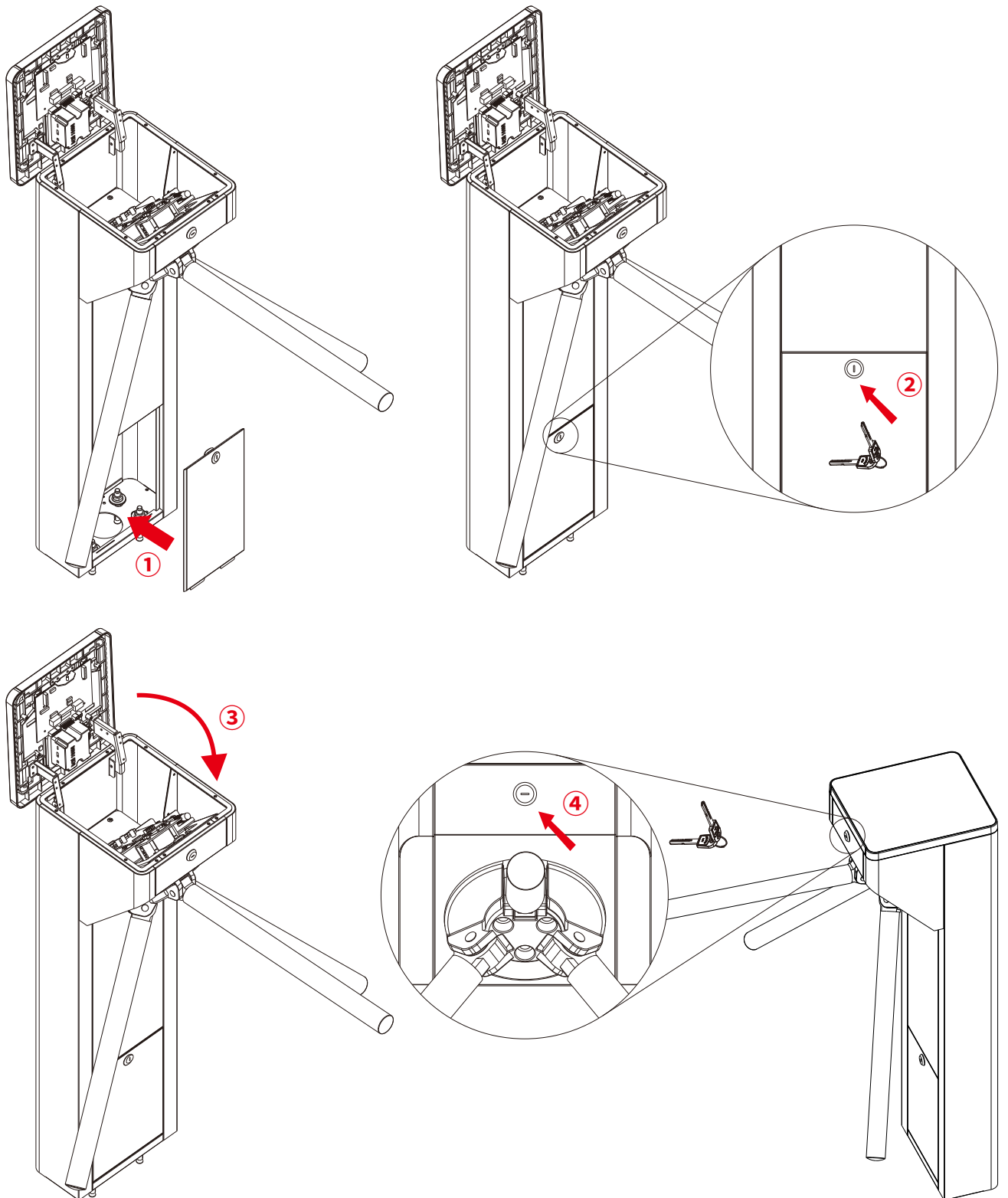

13. We suggest marking a warning line on the floor to remind the user when installation complete. It reminds user to wait outside the warning line until the previous user complete the verification and leave the turnstile.

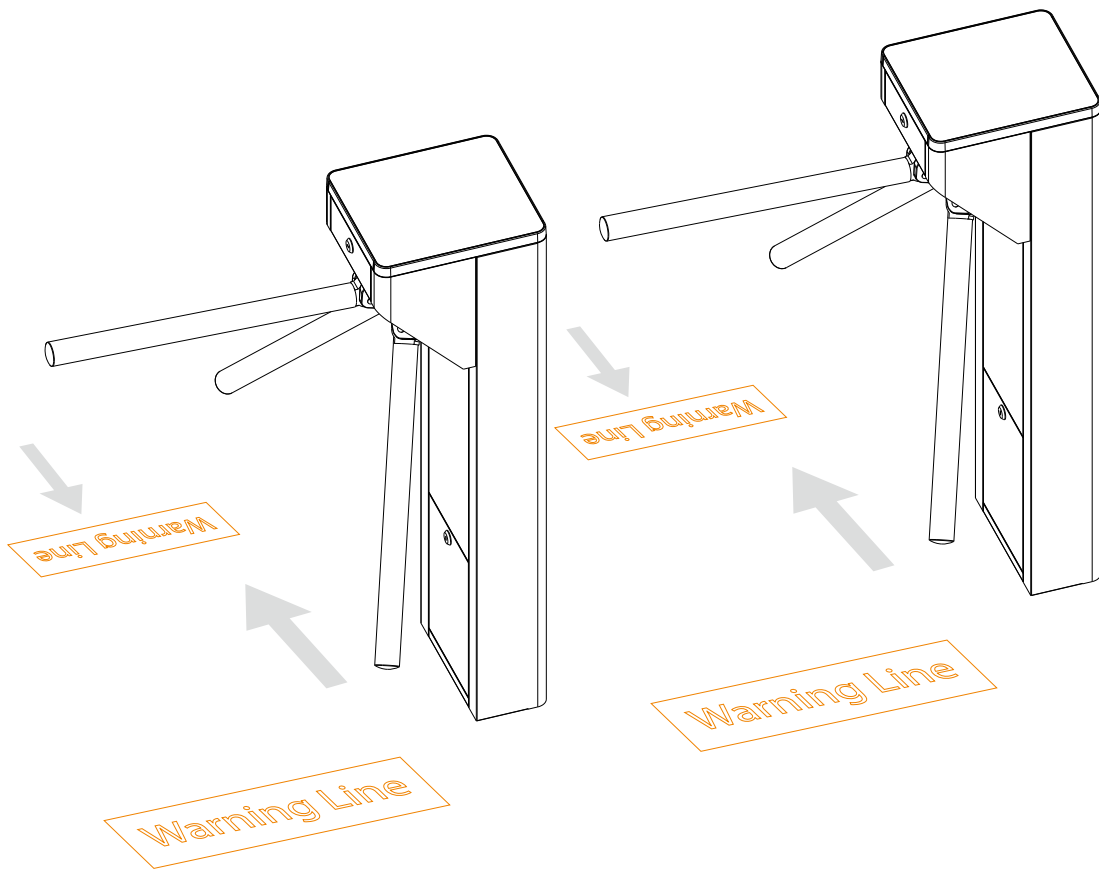

5 Wiring Diagram

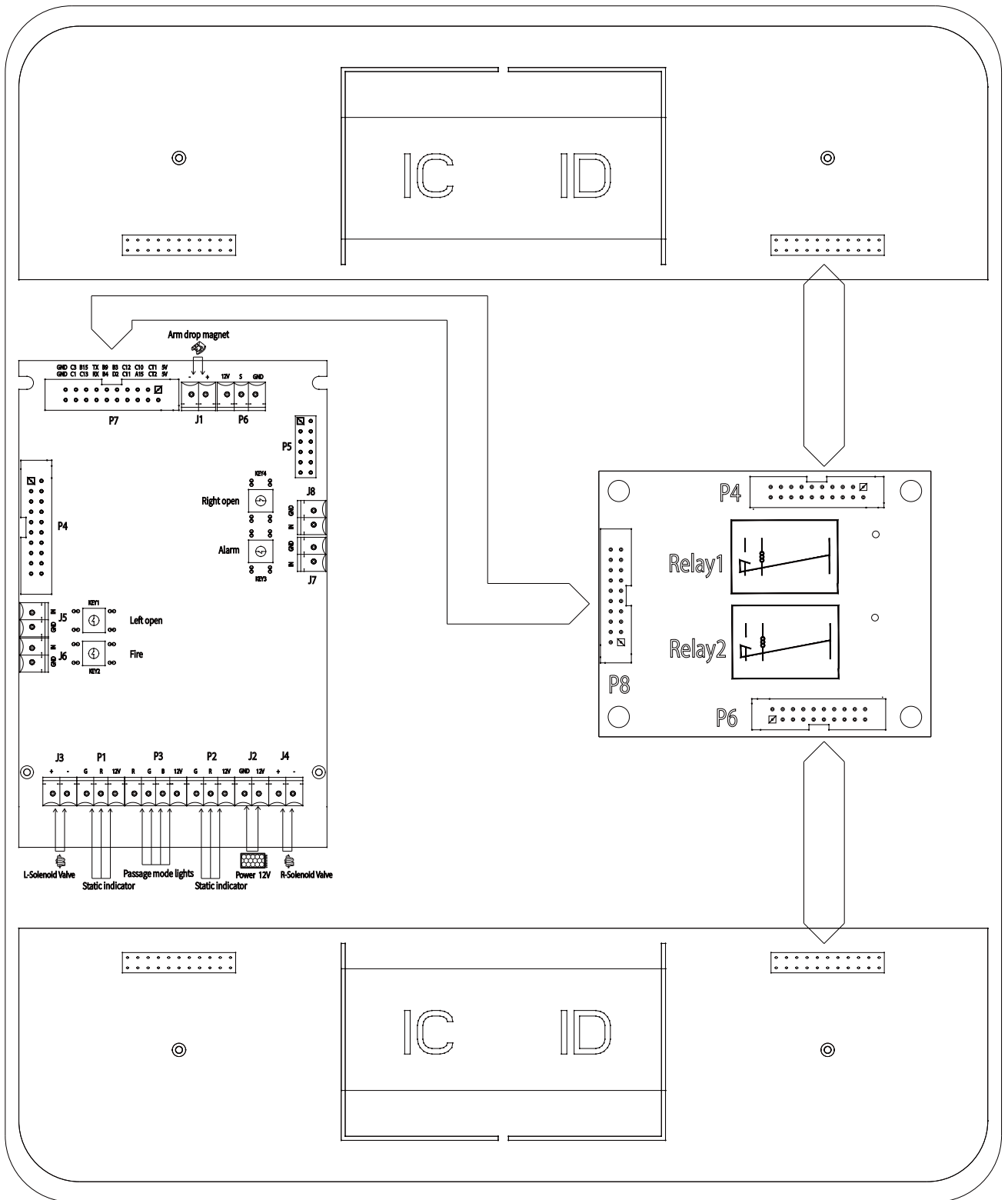

ZKTeco Industrial Park, No. 32, Industrial Road,

Tangxia Town, Dongguan, China.

Phone : +86 769 - 82109991

Fax : +86 755 - 89602394

www.zkteco.com

