

# User Manual

## SBTL500 Series

**Applicable Models: SBTL500, SBTL520**

Date: February 2022

Doc Version: 1.0

English

Thank you for choosing our product. Please read the instructions carefully before operation. Follow these instructions to ensure that the product is functioning properly. The images shown in this manual are for illustrative purposes only.



For further details, please visit our Company's website

[www.zkteco.com](http://www.zkteco.com).

Copyright © 2022 ZKTECO CO., LTD. All rights reserved.

Without the prior written consent of ZKTeco, no portion of this manual can be copied or forwarded in any way or form. All parts of this manual belong to ZKTeco and its subsidiaries (hereinafter the "Company" or "ZKTeco").

## Trademark

**ZKTeco** is a registered trademark of ZKTeco. Other trademarks involved in this manual are owned by their respective owners.

## Disclaimer

This manual contains information on the operation and maintenance of the ZKTeco equipment. The copyright in all the documents, drawings, etc. in relation to the ZKTeco supplied equipment vests in and is the property of ZKTeco. The contents hereof should not be used or shared by the receiver with any third party without express written permission of ZKTeco.

The contents of this manual must be read as a whole before starting the operation and maintenance of the supplied equipment. If any of the content(s) of the manual seems unclear or incomplete, please contact ZKTeco before starting the operation and maintenance of the said equipment.

It is an essential pre-requisite for the satisfactory operation and maintenance that the operating and maintenance personnel are fully familiar with the design and that the said personnel have received thorough training in operating and maintaining the machine/unit/equipment. It is further essential for the safe operation of the machine/unit/equipment that personnel has read, understood and followed the safety instructions contained in the manual.

In case of any conflict between terms and conditions of this manual and the contract specifications, drawings, instruction sheets or any other contract-related documents, the contract conditions/documents shall prevail. The contract specific conditions/documents shall apply in priority.

ZKTeco offers no warranty, guarantee or representation regarding the completeness of any information contained in this manual or any of the amendments made thereto. ZKTeco does not extend the warranty of any kind, including, without limitation, any warranty of design, merchantability or fitness for a particular purpose.

ZKTeco does not assume responsibility for any errors or omissions in the information or documents which are referenced by or linked to this manual. The entire risk as to the results and performance obtained from using the information is assumed by the user.

ZKTeco in no event shall be liable to the user or any third party for any incidental, consequential, indirect, special, or exemplary damages, including, without limitation, loss of business, loss of profits, business interruption, loss of business information or any pecuniary loss, arising out of, in connection with, or

relating to the use of the information contained in or referenced by this manual, even if ZKTeco has been advised of the possibility of such damages.

This manual and the information contained therein may include technical, other inaccuracies or typographical errors. ZKTeco periodically changes the information herein which will be incorporated into new additions/amendments to the manual. ZKTeco reserves the right to add, delete, amend or modify the information contained in the manual from time to time in the form of circulars, letters, notes, etc. for better operation and safety of the machine/unit/equipment. The said additions or amendments are meant for improvement /better operations of the machine/unit/equipment and such amendments shall not give any right to claim any compensation or damages under any circumstances.

ZKTeco shall in no way be responsible (i) in case the machine/unit/equipment malfunctions due to any non-compliance of the instructions contained in this manual (ii) in case of operation of the machine/unit/equipment beyond the rate limits (iii) in case of operation of the machine and equipment in conditions different from the prescribed conditions of the manual.

The product will be updated from time to time without prior notice. The latest operation procedures and relevant documents are available on <http://www.zkteco.com>

If there is any issue related to the product, please contact us.

## ZKTeco Headquarters

**Address**            ZKTeco Industrial Park, No. 32, Industrial Road,  
Tangxia Town, Dongguan, China.

**Phone**             +86 769 - 82109991

**Fax**                 +86 755 - 89602394

For business-related queries, please write to us at: [sales@zkteco.com](mailto:sales@zkteco.com).

To know more about our global branches, visit [www.zkteco.com](http://www.zkteco.com).

## About the Company

ZKTeco is one of the world's largest manufacturer of RFID and Biometric (Fingerprint, Facial, Finger-vein) readers. Product offerings include Access Control readers and panels, Near & Far-range Facial Recognition Cameras, Elevator/floor access controllers, Turnstiles, License Plate Recognition (LPR) gate controllers and Consumer products including battery-operated fingerprint and face-reader Door Locks. Our security solutions are multi-lingual and localized in over 18 different languages. At the ZKTeco state-of-the-art 700,000 square foot ISO9001-certified manufacturing facility, we control manufacturing, product design, component assembly, and logistics/shipping, all under one roof.

The founders of ZKTeco have been determined for independent research and development of biometric verification procedures and the productization of biometric verification SDK, which was initially widely applied in PC security and identity authentication fields. With the continuous enhancement of the development and plenty of market applications, the team has gradually constructed an identity authentication ecosystem and smart security ecosystem, which are based on biometric verification techniques. With years of experience in the industrialization of biometric verifications, ZKTeco was officially established in 2007 and now has been one of the globally leading enterprises in the biometric verification industry owning various patents and being selected as the National High-tech Enterprise for 6 consecutive years. Its products are protected by intellectual property rights.

## About the Manual

This manual introduces the operations of **SBTL500 Series**.

All figures displayed are for illustration purposes only. Figures in this manual may not be exactly consistent with the actual products.

Features and parameters with ★ are not available in all devices.





## Document Conventions

Conventions used in this manual are listed below:

### GUI Conventions

For Software	
Convention	Description
<b>Bold font</b>	Used to identify software interface names e.g. <b>OK, Confirm, Cancel.</b>
>	Multi-level menus are separated by these brackets. For example, File > Create > Folder.
For Device	
Convention	Description
<>	Button or key names for devices. For example, press <OK>.
[ ]	Window names, menu items, data table, and field names are inside square brackets. For example, pop up the [New User] window.
/	Multi-level menus are separated by forwarding slashes. For example, [File/Create/Folder].

### Symbols

Convention	Description
	This represents a note that needs to pay more attention to.
	The general information which helps in performing the operations faster.
	The information which is significant.
	Care taken to avoid danger or mistakes.
	The statement or event that warns of something or that serves as a cautionary example.

## Table of Contents

<b>1 DEVICE OPERATING INSTRUCTIONS.....</b>	<b>6</b>
<b>2 OVERVIEW.....</b>	<b>6</b>
<b>3 FEATURES.....</b>	<b>7</b>
<b>4 TECHNICAL SPECIFICATIONS.....</b>	<b>8</b>
<b>5 APPEARANCE AND DIMENSIONS.....</b>	<b>9</b>
<b>6 PRODUCT COMPONENTS AND WORK PRINCIPLE.....</b>	<b>10</b>
<b>6.1 MECHANICAL SYSTEM.....</b>	<b>10</b>
<b>6.2 ELECTRONIC CONTROL SYSTEM.....</b>	<b>10</b>
<b>6.3 WORKING PRINCIPLE.....</b>	<b>10</b>
<b>6.4 SYSTEM COMPOSITION.....</b>	<b>11</b>
<b>7 FUNCTION INTRODUCTION.....</b>	<b>12</b>
<b>7.1 CARD VERIFICATION.....</b>	<b>12</b>
<b>8 MENU INTRODUCTION.....</b>	<b>13</b>
<b>8.1 PARAMETER SETTINGS DESCRIPTION.....</b>	<b>14</b>
<b>8.2 ERROR CODE AND TROUBLESHOOTING.....</b>	<b>23</b>
<b>9 WIRING DIAGRAM.....</b>	<b>24</b>
<b>10 WARRANTY COVERAGE.....</b>	<b>25</b>

## 1 Device Operating Instructions

- Before the device is put into use, it must first pass the functional commissioning and be put into use only after normal commissioning.
- When the device is powered on, it is strictly forbidden to stand in the channel.
- Pedestrians reading the card to pass, in the direction of the indicator sign does not turn green, is strictly prohibited to enter the channel.
- Do not stay in the channel for long periods of time.
- Through the channel, do not crowd, pedestrians should maintain a certain distance between pedestrians.
- It is strictly forbidden not to swipe the card and pass through the gate quickly.
- Recommended in the device work conspicuously marked this machine pass instructions, guide the passer safely and orderly through the gate channel.
- Device is not working to properly manage the device, knocking, shaking device is strictly prohibited.
- When the device is closed, it is strictly prohibited to push, pull or hit the gate.

**Note:**

1. Do not use the machine when there is lightning, in order to prevent damage to the machine.
2. Make sure that the system protection ground is reliably connected to prevent personal injury.

## 2 Overview

The SBTL500 series multi-functional brushless anti-collision swing barrier turnstile is an intelligent channel management equipment developed and produced by our company for many years. The equipment organically integrates machinery, electronics, microprocessor control and various reading and writing technologies. Through the configuration of various reading and writing equipment, the use of reliable safety protection devices, real-time alarm system and direction indication interface, the intelligent control and management of the channel are jointly coordinated.

The shape of the equipment is stamped and formed of stainless steel plate, which is beautiful in appearance, rust-proof and durable, and adopts standard electrical interface to the outside, which can integrate barcode, ID card, IC card and other card readers on the equipment, providing civilized access to personnel. In addition, the system is also specially designed with functions required for fire

protection, in case of emergency, it can ensure that the passage is unobstructed, and it is convenient for people to evacuate in time.

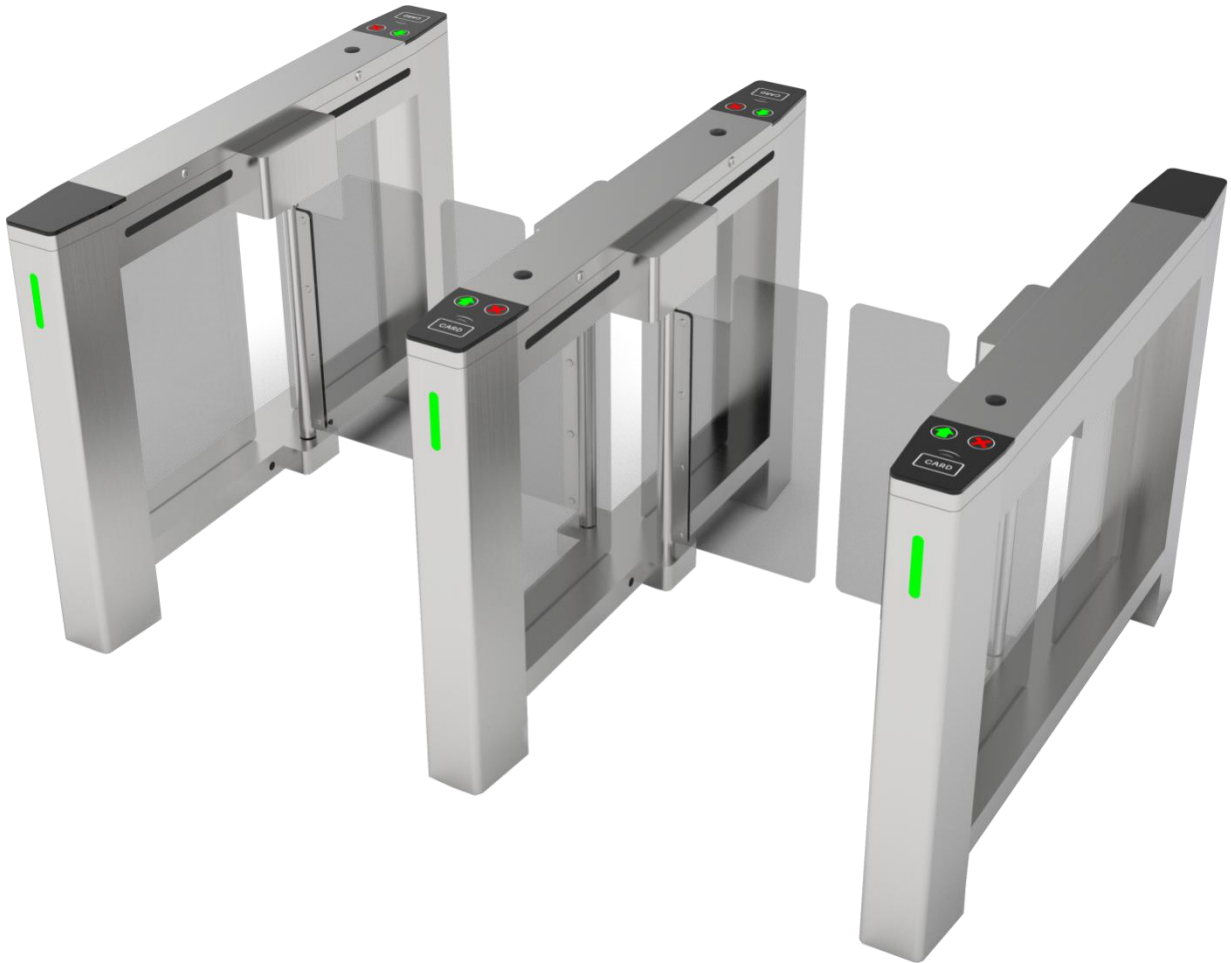

### 3 Features

- It has a clear traffic direction indication function, which is expressed in the form of intuitive LED light indication
- With anti-tailing function: when it is detected that there is a trailing phenomenon in the channel, the system will automatically alarm
- There are a variety of working modes to choose from, which can be one-way traffic, two-way traffic, infrared opening or opening the gate through the control signal to the main board
- With automatic reset function: when the passer does not pass within the specified time after receiving the signal to open the gate, the system will automatically cancel the passer's current access authority
- With voice prompt function
- With zero position self-test function, it is convenient for users to maintain and use



- With anti-pinch action setting function, when people are in the process of passing and the set passing time has expired, it can prevent the swing arm from closing and injuring people
- It has 485 and 232 serial communication functions, and can control the gate opening through the 485/232 serial port
- Anti-collision function: The swing arm will open to form a certain angle when it is impacted. When the external force disappears, the swing arm automatically returns to protect the movement

## 4 Technical Specifications

Feature	Specification
Material thickness	SUS304 stainless steel (top cover) 1.2mm, (body) 1.0mm
Input voltage	AC110V to 220V, 50 Hz to 60Hz
Working temperature	-20 °C to 70°C
Rated power	150W
Speed of throughput	Maximum 30/ minute
Movement life	5 million times
Time of gate opening/Closing	0.6 to 10 seconds (Adjustable)
IR sensor	6 pairs (Scalable)
Communication interface	Optional 232, 485 communication
Swing arm	Standard transparent acrylic; optional stainless steel elbow; swing arm exposed 300mm
Cabinet material	SUS304 stainless steel
Motor	DC brushless motor
Relative humidity	<95%, Non-condensing (*Data from ZKTeco's laboratory)
Working Environment	Indoor/Outdoor (if sheltered)
Dimension(mm)	L=1360, W=280,H=980

## 5 Appearance and Dimensions

SBTL500's appearance and dimensions are shown below:

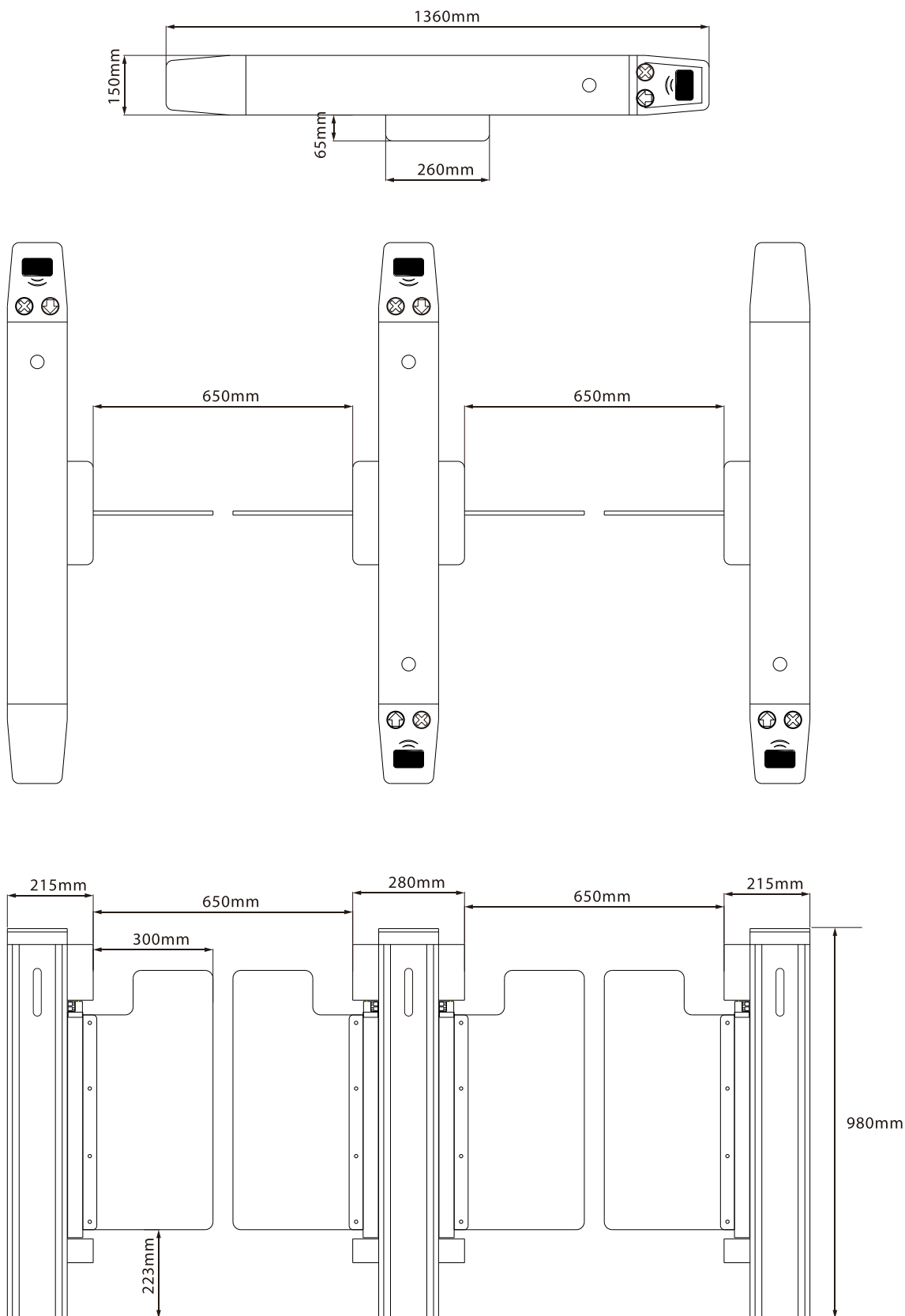

## 6 Product Components and Work Principle

### 6.1 Mechanical System

The mechanical system of the SBTL500 series includes the chassis and the core component. The chassis is a carrier where the Direction indicator, Reader, Infrared sensor, and the Door lock are installed. The core component mainly consists of the Motor, Frame, Bearing, and swing Arm.

### 6.2 Electronic Control System

The electronic control system of a swing barrier turnstile is mainly composed of the Card Reader, Turnstile control board, Infrared Sensor, Direction Indicator and Alarm.

**Reader:** The reader reads the data in the card and sends it to the Access Controller.

**Turnstile control board:** The turnstile control board is the system's control center that receives signals from the reader and the photoelectric switch performs logical calculation and processing of these signals and sends executive commands to the Direction indicator, electric motor and the alarm.

**Infrared sensor:** It detects the position of the pedestrian and plays the role of safety protection.

**Direction indicator:** This indicator displays the pedestrian passage path and directs them to pass through the lane in a safe and orderly manner.

**Alarm:** The alarm gives an alarm voice if the system detects any unauthorized entry to the passage.

### 6.3 Working Principle

1. After powering on to the device, the system performs the Power-On Self-Test. (The turnstile control board self-checks whether the infrared sensor is normal, the driver drives the motor to rotate left and right and calculates to find the zero position)
2. After the Power-On Self-Test is completed, the system will be prompted to start and the device will enter the standby state (if a fault is detected, the cause of the fault will be broadcast by voice, and the components corresponding to the cause will be manually checked to see if the wiring is normal, and the device will be restarted after adjustment).
3. When a valid Card detected, the buzzer will give a positive audible prompt to the pedestrian, indicating that successfully verified. And then, the reader sends signals to the Access Controller to request permission to pass through the passage. The Access Controller will send the signal to the master control panel.

4. After receiving the signal from the Access Controller, the turnstile control board sends valid control signals to the direction indicator and the electric motor. At last the direction arrow turns green.
5. Pedestrians pass through the passage according to the direction indicator signs. Infrared sensors keep on detecting the pedestrian during the whole process, and continue to send signal to the master control board until the pedestrian passes completely through the passage.
6. If the pedestrian enters the passage but forgets to verify identification, or if the card held by the pedestrian is invalid, the system will prompt an audible alarm to stop and retreat the pedestrian from the passage. The pedestrian can pass through the passage only after a valid card is successfully verified.

## 6.4 System Composition

The single-lane management system is composed of two single-core swing barriers. The multi-lane management system is composed of two single-core barriers and multiple dual-core barriers.

### Working modes of the system

To make the product more versatile, this system provides multiple working modes for the user, including Normal working mode, Normally open mode, Normally close mode and Testing mode.

**Normal Working Mode:** In this working mode, the turnstile works normally.

**Normal Open Mode:** In this working mode, the turnstile is always open.

**Normal Close Mode:** In this working mode, the turnstile is always closed.

**Testing Mode:** In this working mode, the turnstile performs auto-test.

## 7 Function Introduction

### 7.1 Card Verification

The Card Verification mode compares the card number in the card induction area with all the card number data registered in the device and sends it to the Access Controller.

The device enters the card authentication mode when a user presses his/her card to the card reading area.

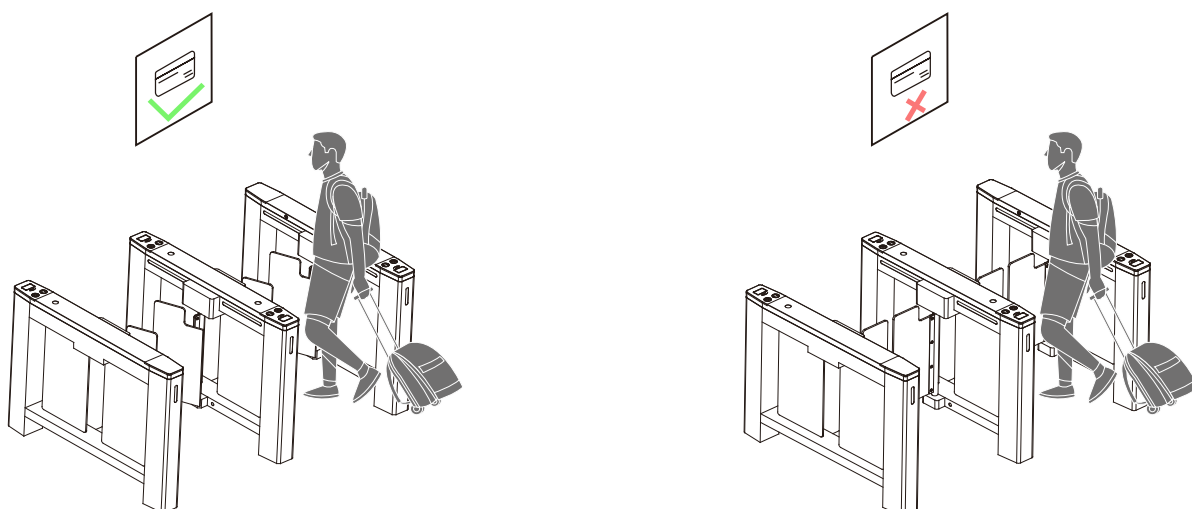
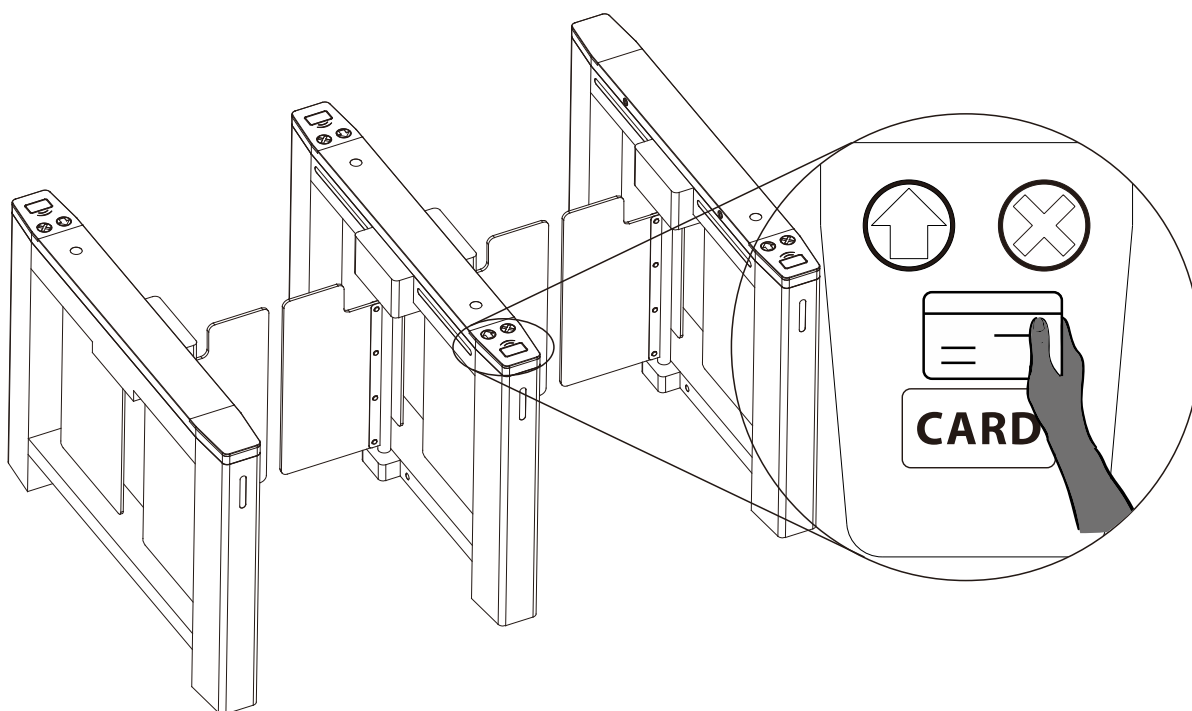

## 8 Menu Introduction

There are 4 buttons on the control panel, "MENU", "▲", "▼" and "ENT".

**MENU:** It is used for enter the settings menu.

**▲:** It is used to scroll up menus and increase parameter/value.

**▼:** It is used for flip down the menus and decrease parameter/value.

**ENT:** It is used for confirm the current modified value.

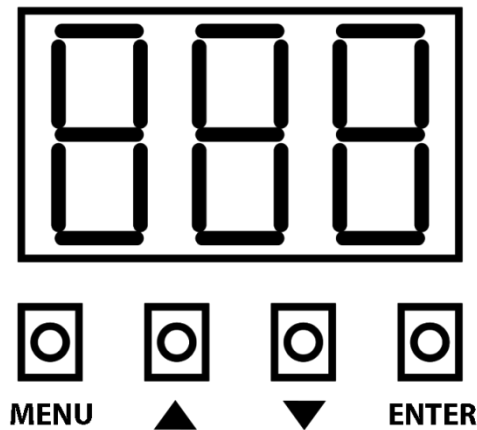

**Note:**

1. In standby, long press the "ENT" button to enter the digital display and turn it into 3 horizontal bars, then press the "▲" and "▼" buttons for a total of more than 3 times, press the "ENT" button to restore the factory settings.
2. Since the turnstile control board is in one control and two mode, the user should use at least one power supply of 24V/6.5 amps or above (when the output power of the power supply is not matched enough and the running current overload will cause the power supply to start frequently, the greater the output power of the power supply, the greater the resistance of the motor).

## 8.1 Parameter Settings Description

Item	Description	Default
L-1	<p><b><u>The Opening Time of the Inbound and Outbound (Unit: second)</u></b></p> <p>Set the length of time after the gate is opened and no one passes, the gate will automatically close. The opening time of the inbound and outbound can be set between 0 to 99 and the default value is 6.</p>	6
L-2	<p><b><u>Working Modes of the Turnstile</u></b></p> <p>Set the turnstile opening method, for infrared opening, or swipe card to open (Default all swipe card).</p> <ul style="list-style-type: none"> <li>• <b>0:</b> Swipe the card on the left and right</li> <li>• <b>1:</b> Infrared on left, swipe the card on the right</li> <li>• <b>2:</b> Swipe the card on the left, Infrared on right</li> <li>• <b>3:</b> Infrared on left and right</li> </ul>	0
L-3	<p><b><u>Delay Closing Time (Unit: second)</u></b></p> <p>It is used to set how long to close the gate after pedestrians pass through the gate normally, the default is 0, no delay, that is, the gate will be closed immediately after pedestrian pass through. The delay closing time can be set between 0.1 to 99.9 and the default value is 6.</p>	0.2
L-4	<p><b><u>Left Passage Voice</u></b></p> <p>Set the voice to be played by the channel when passing from the left. For example, you can set the turnstile to play "Welcome" when you pass from the left. The valid value of the volume that can be set is 1 to 40.</p>	1
L-5	<p><b><u>Right Passage Voice</u></b></p> <p>Set the voice to be played by the channel when passing from the right. For example, you can set the turnstile to play "Have a safe trip" when you pass from the right. The valid value of the volume that can be set is 1 to 40.</p>	15

<p><b>L-6</b></p>	<p><b><u>Infrared Stacking Time (Unit: second)</u></b></p> <p>Set the time allowed to block 2 infrareds at the same time, due to the short spacing between some turnstile infrared (such as the left infrared and anti-pinch is very close), to prevent the human body from blocking 2 infrared voices at the same time will be a false alarm. The infrared stacking time can be set between 0 to 30 and the default value is 3.</p>	<p><b>3</b></p>
<p><b>L-7</b></p>	<p><b><u>Power Failure Opening Direction</u></b></p> <ul style="list-style-type: none"> <li>● <b>0:</b> Left open</li> <li>● <b>1:</b> Right open</li> </ul>	<p><b>0</b></p>
<p><b>L8</b></p>	<p><b><u>Alarm Voice</u></b></p> <ul style="list-style-type: none"> <li>● <b>0:</b> Please swipe your card for illegal entry</li> <li>● <b>1:</b> Didi</li> </ul>	<p><b>0</b></p>
<p><b>L-9</b></p>	<p><b><u>Inbound/Outbound Memory Function Configuration</u></b></p> <p>When opening or closing the inbound/outbound pass whether it has memory function, which is generally used for swiping the card to open the gate, in the case of one person swiping the card has not passed, whether the memory of other people swiping the card. " Without" means the first person swipe the card through, the second person swipes the card to be effective; "With" is how many people swipe the card that allows the number of consecutive people through.</p> <ul style="list-style-type: none"> <li>● <b>0:</b> Without memory function</li> <li>● <b>1:</b> With memory function</li> </ul>	<p><b>0</b></p>
<p><b>L-10</b></p>	<p><b><u>Infrared Anti-pinch Action</u></b></p> <ul style="list-style-type: none"> <li>● <b>0:</b> Emergency stop and open the gate</li> <li>● <b>1:</b> Emergency stop and remain stationary</li> </ul>	<p><b>0</b></p>



L-11	<p><b><u>Infrared Quantity</u></b></p> <ul style="list-style-type: none"> <li>● 0: 4 pairs</li> <li>● 1: 6 pairs</li> </ul>	0
L-12	<p><b><u>Voice Volume</u></b></p> <p>Adjust the volume of the device, the larger the number is set, the louder the volume. The valid value for Volume Setting can be set between 0 to 15 and the default value is 15.</p>	15
L-13	<p><b><u>Voice Test</u></b></p> <p>To automatically test whether the audio files stored in the device are complete and the voice quality is good. Press "ENT" button to exit.</p>	
L-14	<p><b><u>Aging Test</u></b></p> <p>The aging test project refers to the process of simulating the various factors involved in the actual use conditions of the product to carry out the corresponding condition strengthening experiment for the aging of the product. The experiment is mainly aimed at plastic materials. Press "ENT" button to test, press "MENU" to exit.</p>	
L-15	<p><b><u>Main Motor Brand Selection: Motherboard Appears E-1 to 1</u></b></p> <ul style="list-style-type: none"> <li>● 0:-</li> <li>● 1:-</li> </ul>	0
L-16	<p><b><u>Slave Motor Brand Selection: Motherboard Appears E-2 to 1</u></b></p> <ul style="list-style-type: none"> <li>● 0:-</li> <li>● 1:-</li> </ul>	0
L-17	<p><b><u>Reverse Gate Closing Option</u></b></p> <ul style="list-style-type: none"> <li>● 0: No Close</li> <li>● 1: Close</li> </ul>	0

L-18	<p><b><u>Two-color Light Tri-color Light Control Options</u></b></p> <ul style="list-style-type: none"> <li>● <b>0:</b> Two-color light</li> <li>● <b>1:</b> Tri-color light</li> </ul>	<b>0</b>
L-19	<p><b><u>Can the Gate be Opened in the Channel</u></b></p> <ul style="list-style-type: none"> <li>● <b>0:</b> The channel can be swiped to open the gate</li> <li>● <b>1:</b> The channel can not be swiped to open the gate</li> </ul>	<b>0</b>
L-20	<p><b><u>Flap Barrier IR Setting</u></b></p> <p>This function can be set in the flap barrier mode for pedestrian to pass the last pair of infrared gates or to pass the anti-pinch infrared gate. (Default over the last pair of infrared gates)</p> <ul style="list-style-type: none"> <li>● <b>0:</b> Close the gate after the pedestrian has passed the anti-pinch</li> <li>● <b>1:</b> Close the gate after the pedestrian has passed the last pair of IR</li> </ul>	<b>0</b>
L-21	<p><b><u>Infrared Anti-trailing Whether to Open</u></b></p> <ul style="list-style-type: none"> <li>● <b>0:</b> Close</li> <li>● <b>1:</b> Open</li> </ul>	<b>0</b>
L-22	<p><b><u>Whether to Close the Gate After Anti-trailing</u></b></p> <ul style="list-style-type: none"> <li>● <b>0:</b> Alarm, no close the gate</li> <li>● <b>1:</b> Alarm, close the gate</li> </ul>	<b>0</b>
L-23	<p><b><u>Gate Open Stay Time</u></b></p> <p>The larger the value, the longer the gate stays open, and the smaller the value, the faster it closes. The valid value for Gate Open Stay Time can be set between 0 to 999 and the default value is 5.</p>	<b>5</b>

<b>L-24</b>	<p><b><u>Alarm Voice of Anti-trailing</u></b></p> <p>The larger the number is set, the louder the volume. The valid value for Alarm Voice of Anti-trailing can be set between 0 to 41 and the default value is 0.</p>	<b>0</b>
<b>L-25</b>	<p><b><u>Alarm Voice of False Direction</u></b></p> <p>The larger the number is set, the louder the volume. The valid value for Alarm Voice of False Direction can be set between 0 to 41 and the default value is 0.</p>	
<b>L-26</b>	<p><b><u>Alarm Voice of Stagnation</u></b></p> <p>The larger the number is set, the louder the volume. The valid value for Alarm Voice of Stagnation can be set between 0 to 41 and the default value is 0.</p>	<b>0</b>
<b>D-1</b>	<p><b><u>Zero Position</u></b></p> <p>If the gate is not aligned, adjust the motor shaft to swing the flap to the desired closing position.</p>	-
<b>D-2</b>	<p><b><u>Left Gate Position Setting</u></b></p> <p>Adjust the motor shaft to swing the flap to the desired closing position.</p>	-
<b>D-3</b>	<p><b><u>Right Gate Position Setting</u></b></p> <p>Adjust the motor shaft to swing the flap to the desired closing position.</p>	-
<b>D-4</b>	<p><b><u>Speed of Opening/Closing Setting</u></b></p> <p>Set the speed of opening or closing the gate, the smaller the value the faster the opening/closing speed, the larger the value the slower the opening/closing speed. The valid value for Speed of Opening/Closing Setting can be set between 1 to 10 and the default value is 3.</p>	<b>3</b>

<p><b>D-5</b></p>	<p><b><u>Gate Type</u></b></p> <p>Set the type of gates, there are two types of gates: "flap barrier" and "swing barrier"; what turnstile should be set to the corresponding type to work properly.</p> <ul style="list-style-type: none"> <li>● <b>0:</b> Swing barrier</li> <li>● <b>1:</b> Flap barrier</li> </ul>	<p><b>0</b></p>
<p><b>D-6</b></p>	<p><b><u>With or Without Clutch</u></b></p> <ul style="list-style-type: none"> <li>● <b>0:</b> No</li> <li>● <b>1:</b> Yes</li> </ul>	<p><b>0</b></p>
<p><b>D-7</b></p>	<p><b><u>Rebound Mode</u></b></p> <ul style="list-style-type: none"> <li>● <b>0:</b> Swing Arm bounces back when it touches a pedestrian and continues to open the gate for the pedestrian.</li> <li>● <b>1:</b> After Swing Arm touches a pedestrian, it will stop for a while and then bounce back and continue to open the gate for the pedestrian.</li> </ul>	<p><b>0</b></p>
<p><b>D-8</b></p>	<p><b><u>Confrontation Strength</u></b></p> <p>The larger the value, the greater the counteracting force, and the smaller the value, the smaller the counteracting force. The valid value for Confrontation Strength can be set between 1 to 20 and the default value is 10.</p>	<p><b>10</b></p>
<p><b>D-9</b></p>	<p><b><u>Reset Time</u></b></p> <p>The valid value for Reset Time can be set between 0 to 40 and the default value is 0.</p>	<p><b>0</b></p>
<p><b>D-10</b></p>	<p><b><u>Master Gate Closing Buffer Strength</u></b></p> <p>The higher the value, the greater the strength in place. The valid value for Master Gate Closing Buffer Strength can be set between 1 to 100 and the default value is 50.</p>	<p><b>50</b></p>

D-11	<p><b><u>Master Motor Speed</u></b></p> <p>The larger the value, the faster the motor speed, and the smaller the value, the slower the motor speed. The valid value for Master Motor Speed can be set between 1 to 100 and the default value is 65.</p>	65
D-12	<p><b><u>Slave Gate Closing Buffer Strength</u></b></p> <p>The higher the value, the greater the strength in place. The valid value for Slave Gate Closing Buffer Strength can be set between 1 to 100 and the default value is 50.</p>	50
D-13	<p><b><u>Slave Motor Speed</u></b></p> <p>The larger the value, the faster the motor speed, and the smaller the value, the slower the motor speed. The valid value for Slave Motor Speed can be set between 1 to 100 and the default value is 65.</p>	65
D-14	<p><b><u>Power Supply</u></b></p> <p>The valid value for Power Supply can be set between 1 to 10 and the default value is 5.</p>	6
D-15	<p><b><u>Power-on Zero Position Speed</u></b></p> <p>The larger the value, the faster it is to find the zero position, and the smaller the value, the slower it is to find the zero position. The valid value for Power-on Zero Position Speed can be set between 1 to 10 and the default value is 5.</p>	5
D-16	<p><b><u>Flap Barrier Zero Position Direction</u></b></p> <p>If the flap barrier position is not correct, please adjust to 1. Here there is 0 or 1 adjustable.</p>	0
D-17	<p><b><u>Physical Anti-pinch Sensitivity</u></b></p> <p>The larger the value the less sensitive the physical anti-pinch, the smaller the value the more sensitive the anti-pinch. The valid value for Physical Anti-pinch Sensitivity can be set between 1 to 99 and the default value is 75.</p>	75

D-18	<p><b><u>Physical Anti-pinch Current Time</u></b></p> <p>The larger the value the less sensitive the physical anti-pinch, the smaller the value the more sensitive the anti-pinch. The valid value for Physical Anti-pinch Current Time can be set between 1 to 99 and the default value is 10.</p>	10
D-19	<p><b><u>Acceleration Current</u></b></p> <p>The larger the value, the faster the motor starts, and the smaller the value, the slower the motor starts.</p>	160
D-20	<p><b><u>Acceleration Current Time</u></b></p> <p>The larger the value, the faster the motor starts, and the smaller the value, the slower the motor starts.</p>	10
D-21	<p><b><u>Clutch Suction Angle</u></b></p> <p>The larger the value, the larger the suction angle, the smaller the value, the smaller the suction angle.</p>	15
D-22	<p><b><u>Duty Cycle of Clutch Adjustment</u></b></p>	10
D-23	<p><b><u>Physical Anti-pinch Reaction Time</u></b></p> <p>The larger the value, the slower the reaction speed. The smaller the value, the faster the reaction speed.</p>	0
D-24	<p><b><u>Plugging Sensitivity</u></b></p> <p>The larger the value, the longer the plugging, and the smaller the value, the shorter the plugging.</p>	2
D-25	<p><b><u>Duration of Current Protection</u></b></p> <p>The larger the value, the longer the protection time, and the smaller the value, the shorter the protection time.</p>	2

<b>D-26</b>	<p><b><u>Confrontation Strength of Slave</u></b></p> <p>The larger the value, the greater the counteracting force, and the smaller the value, the smaller the counteracting force. The valid value for Confrontation Strength can be set between 1 to 20 and the default value is 10.</p>	<b>13</b>
<b>D-27</b>	<p><b><u>Closing Deceleration Distance</u></b></p> <p>The larger the number, the longer the deceleration time and the more stable the swing arm operation.</p>	<b>8</b>

### Common Problems

1. If the digital tube appears E-1 or E-2, that the motor type is not correct, L15, L16 tuned to 1.
2. If the gate keeps opening and closing, please adjust D-23 to 0.
3. If the two gates are not synchronized, by adjusting D-11 master motor speed and from the master motor speed D-13, that speed is fast to adjust that small.

### How to Set Up the Movement with Clutch

1. D-6 Change to 1
2. D-8 Change to 2
3. D-9 change to 4
4. D-10 D-12 changed to 15, the premise requires the concentricity of the movement to do a good job, or the gate will appear constantly switch.

If you want fast, please use 24V 10A switching power supply, D19 changed to 300.

### Flap Barrier Commissioning Instructions

The motor needs to use 3000 rpm 30K brush motor

1. D-4 to 1
2. D-5 to 1
3. D-10 to 90 D-12 to 90
4. D-19 to 230

If the flap barrier zero position is not correct in the open position, D-16 is set to 1.

## 8.2 Error Code and Troubleshooting

Display E-1 Master Motor Hall Error Adjustment L-15 to 1

Display E-2 Slave Motor Hall Error Adjustment L-16 to 1

//---Door status		
<b>#define</b>	Door_Colse	0 //Close to Limit
<b>#define</b>	Door_AOpen	1 //AOpen to Limit
<b>#define</b>	Door_BOpen	2 //BOpen to Limit
<b>#define</b>	Door_AOpening	3 //AOpening
<b>#define</b>	Door_BOpening	4 //BOpening
<b>#define</b>	Door_AColseing	5 //AClosing
<b>#define</b>	Door_BColseing	6 //BClosing
<b>#define</b>	Door_Init	7 //Initialize
<b>#define</b>	Door_SC	8 //Brake
<b>#define</b>	Door_Find_ZERO	9 //Looking for zero
<b>#define</b>	Door_emergency_stop	10// Emergency stop condition
<b>#define</b>	Door_A_Close_Emer_Stop	11//A In emergency
<b>#define</b>	Door_B_Close_Emer_Stop	12//B In emergency
<b>#define</b>	Door_A_Opening_Stall	13// Open the gate A in the plug turn
<b>#define</b>	Door_B_Opening_Stall	14 // Open the gate B in the plug turn
<b>#define</b>	Door_A_Closeing_Stall	15//Close the gate A in the plug turn
<b>#define</b>	Door_B_Closeing_Stall	16//Close the gate B in the plug turn
<b>#define</b>	Door_Emer_After_Close	17



# 9 Wiring Diagram

Check circuit according to the following wiring diagram:

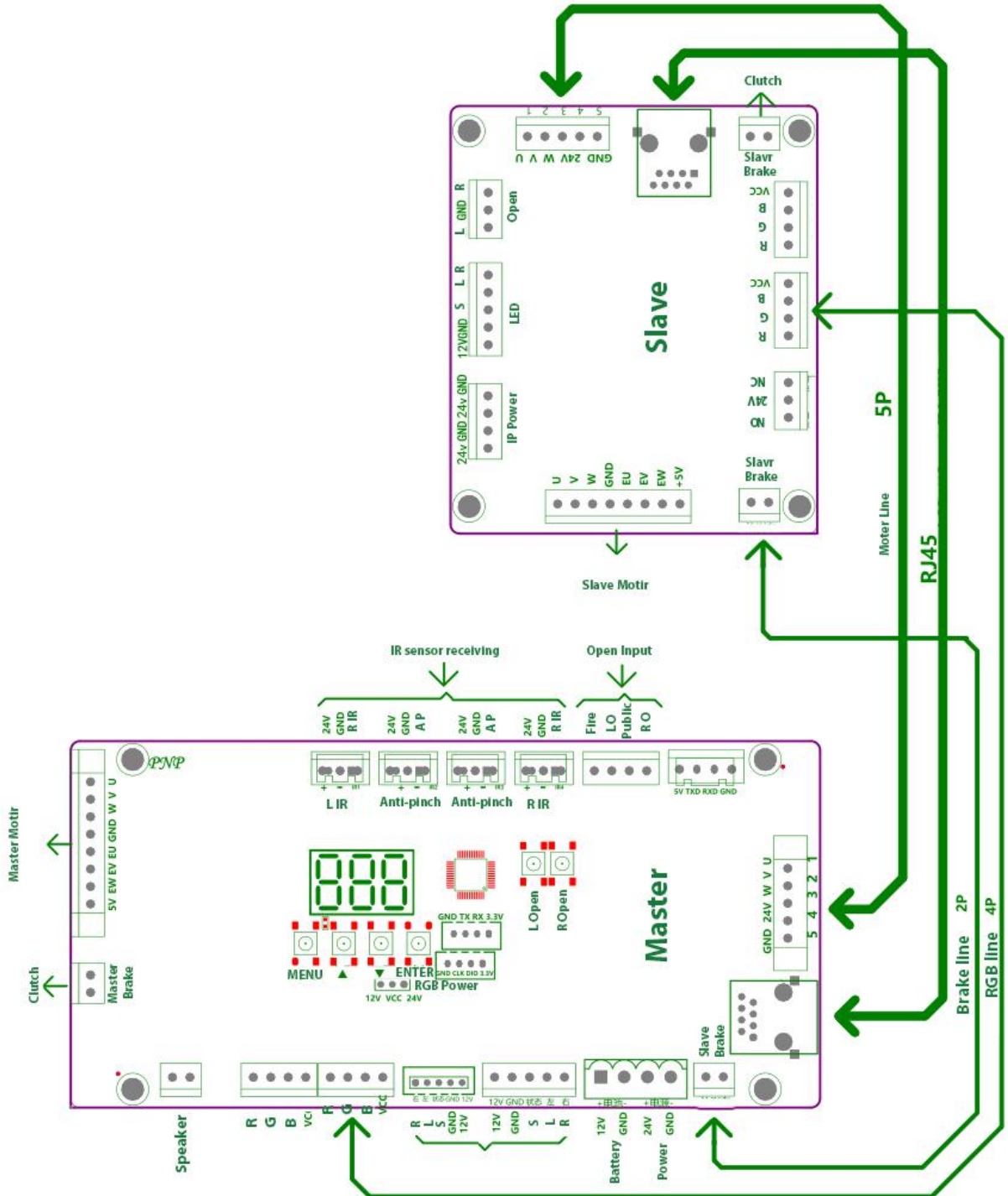

## 10 Warranty Coverage

Damage that occurs during the normal use of the product is covered by the warranty and enjoys warranty service.

If the damage caused by the following circumstances, belong to the non-warranty scope.

1. Damage caused by incorrect operation in violation of the operating procedures.
2. Damage caused by unauthorized maintenance of the product.
3. Abnormalities and damage caused by the use of very poor conditions and the use of the environment

ZKTeco Industrial Park, No. 32, Industrial Road,

Tangxia Town, Dongguan, China.

Phone : +86 769 - 82109991

Fax : +86 755 - 89602394

[www.zkteco.com](http://www.zkteco.com)

